

HA22E

DATA SHEET

Models

Electric Input, Single Acting
(Spring Loaded) Servo

Electric Input, Double Acting
(Differential) Servo



Application

- HA22E Hydraulic Amplifier provides the force to operate the control valve of steam turbines or fuel control linkages of large reciprocating engines.
- The electrically controlled HA22E Amplifier is a pilot operated linear servo actuator, which is used in conjunction with the Si-TEC Xtend CGC/CGC-ET governor (0 – 200 mA output), Woodward electronic governors, etc.

Key features

Optimum transient & steady state response

Minimal overshoot

Shock resistant cast iron casing

Billet power piston & output shaft

Output shaft support bush (oil fed)

Wear preventative coating for extended service life

Oil accumulator for internal actuator

High efficiency oil motor

Optional oil filter for internal actuator

Input

- Resistance: 30 – 35 Ohms at 20 °C (68 °F)
- Maximum allowable current: 400 mA
- Typical operating current range: 25 – 160 mA
- Plug receptacle: 4-pin MS-3102C-145-2P
- Ex. Proof Conn: UL/CSA Class I & II, Grp. C, D, E, F & G

Output

- Piston size: 184.2 mm (7.25") diameter.
- Maximum stroke: 76.2 mm +/- 0.76 mm (3.00" +/- 0.03")
- Rod size: 38.1 mm (1.5") diam. width 1.00" – 12 UNF thread
- Maximum stalling force (lbs.) in increase direction:

Single-Acting Servo

- 39.8P – (F1 + KX)
P = supply pressure
F1 = spring preload
K = spring scale
X = amplifier stroke

Double-Acting Servo

- 24.5P
where P = supply pressure
- Maximum side load on output shaft: 170 kg (375 lbs.)

Typical calibration (min. & max. range)

- 25 mA input: 3.8 mm (0.15 ") output travel
- 160 mA input: 69.1 mm (2.72 ") output travel

Control quality

- Time constant: Around 0.025 seconds
- Hysteresis: Within 0.25 %

Construction

- Cover: Cast aluminium
- Case: Cast ductile iron
- Output rod: Hardened and ground steel
- Mass/weight: 120 kg (264 lbs)

Mounting

- Attitude: Vertical or horizontal with pilot valve above servo
- Mounting bolts: 0.625 diameter (4)

Hydraulic supply

- Type: Petroleum based oils
- Source: Prime mover lubricating system or external supply
- Operating supply pressure: 800 to 3500 kPa (116 to 508 PSI)
- Flow rate: 760 L/min (200 gpm) during speed transients (requires accumulator 9.5 L/min.); less than 15 L/min at 1035 kPa (150 psi) steady state leakage
- Supply filters: 10 – 15 microns (nominal)
- Viscosity: Up to 3000 SSU, but the normal performance is based on 50 to 2000 SSU
- Operating temperature: -30 to +120 °C

Hydraulic fittings

- Supply inlet: 1.625 – 12 UN 2B thread, 0.906 deep
- Drain: Internal drain through case bottom. Optional 1.3121 – 12 UN 2B thread, each side of case are both normally plugged
- Starting oil inlet: 0.562 – 18 UNF 2B thread. Inlet is normally plugged

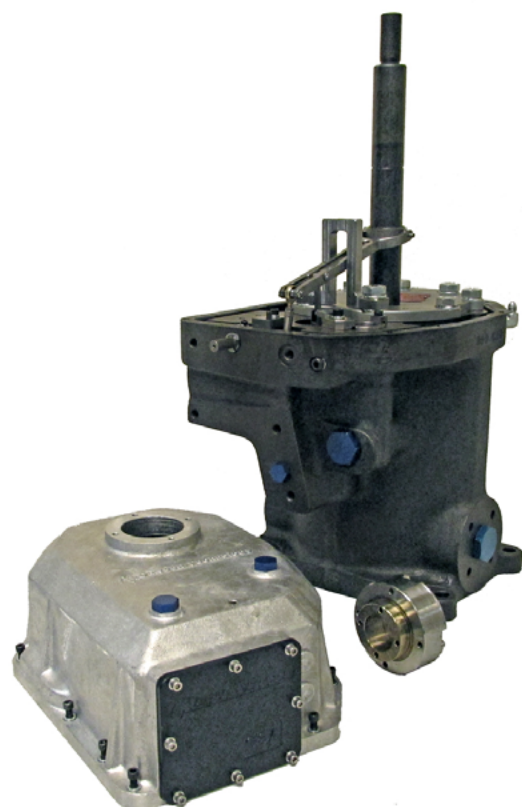

HA 22E Hydraulic Amplifier (elec. input) - dimensions & physical outline

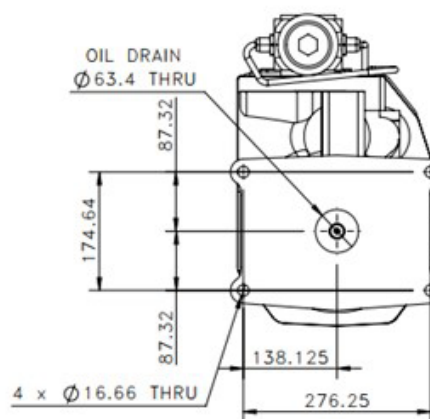
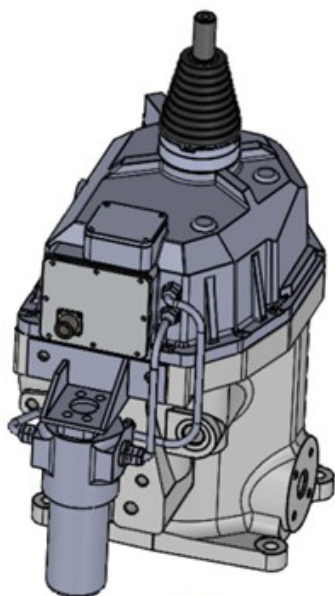
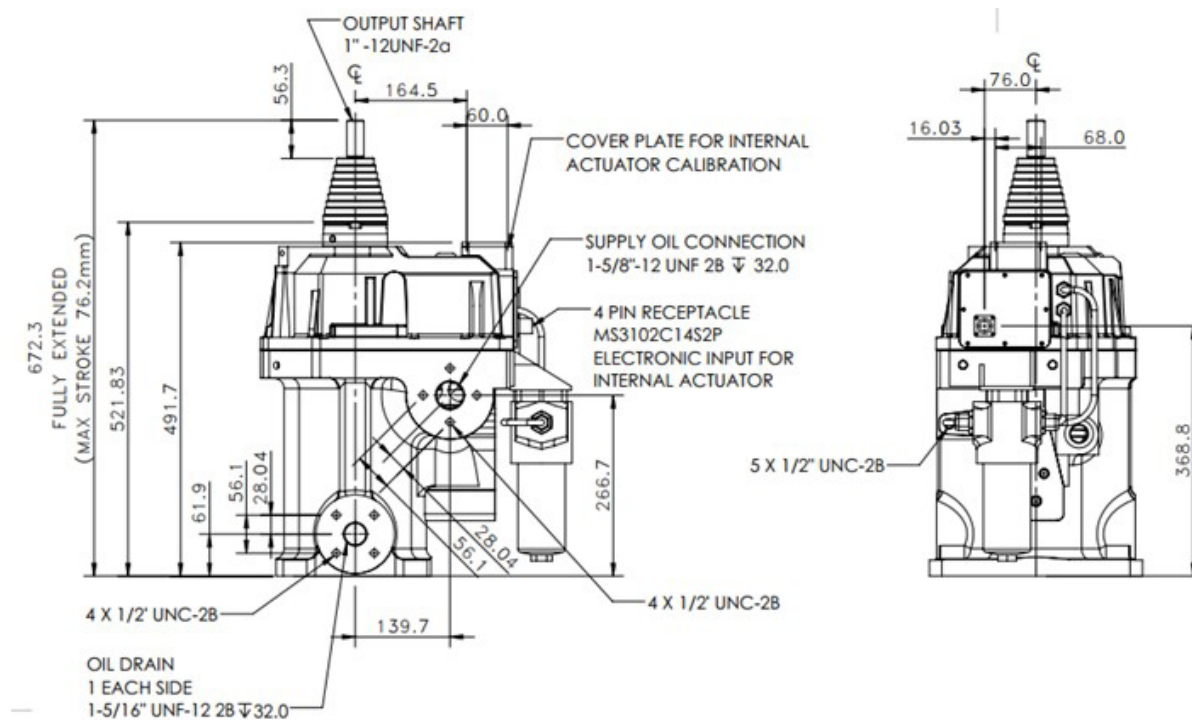

UNLESS OTHERWISE SPECIFIED DIMENSIONS ARE IN MILLIMETERS

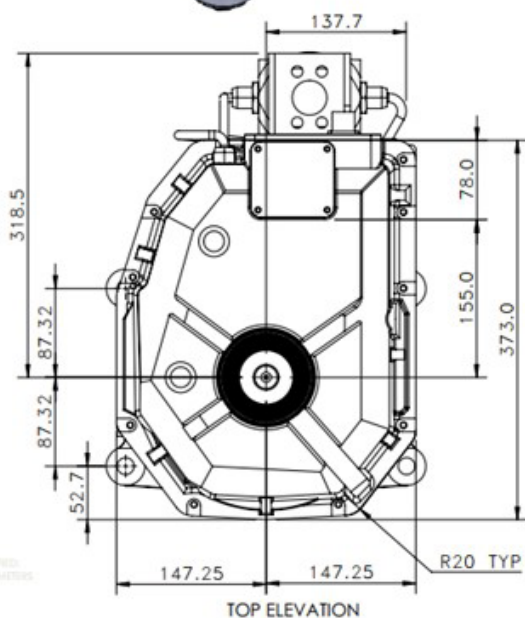

ESPECIALLY FOR DIMENSIONS

